

SATRON VV pressure transmitter

BLV810
March 1, 2005

SATRON VV pressure transmitter belongs to V-transmitter family. The series V transmitters have both analog and smart properties. SATRON VV is used for 0-4 kPa...0-0.2 MPa ranges. The transmitter communicates in a 2-wire system.

SATRON VV pressure transmitter is suitable for liquid level measurements in ground and rock tanks, and in open channels and ships' tanks. SATRON VV pressure transmitter can be used in corrosive conditions and to measure contaminating liquids. Possible foam on the surface of the measured liquid does not disturb the measurement. SATRON VV does not require compressed air supply.

The transmitter's sensor is piezoresistive. The rangeability is 25:1. The transmitter communicates digitally using the HART® protocol.



TECHNICAL SPECIFICATIONS

Measuring range and span

See Selection Chart.

Zero and Span adjustment

Zero elevation: Calibrated span is freely selectable on the specified range depending from the desired option. This can be made by using external control shafts (analog option), keyboard (display option) or HART®275 communicator.

Damping

Time constant is continuously adjustable 0,01 to 60 s.

Temperature limits

Process: -10 to +80 °C

Ambient: -30 to +80 °C

Shipping and storage: -40 to +80 °C.

Equipment cabinet is recommended for extremely demanding conditions.

Pressure limits

Min. and max. process pressure: See the appended tables.

Output 2-wire (2W), 4-20 mA, user selectable for linear, square root, inverted signal or the transfer function (16 points) specified by the user

Supply voltage and permissible load

See the load capacity diagram; 4-20 mA output: 12-35 VDC.

Humidity limits 0-100 % RH; freezing of condensed water not allowed in reference pressure channels.

PERFORMANCE SPECIFICATIONS

Tested in accordance with IEC770:

Reference conditions, specified span, no range elevation, AISI316L diaphragm, silicone oil fill.

Accuracy

- ±0.1 % of calibrated span (span 1:1-7.5:1 / max.range).
On the measuring ranges 7.5:1-25:1:
$$\pm [0.01 + 0.012 \times \left(\frac{\text{max. span}}{\text{calibrated span}} \right)] \% \text{ of calibrated span}$$

(incl. nonlinearity, hysteresis and repeatability)

Long-term stability

±0.1 % of max. span per 12 months

Temperature effect on compensated temperature ranges

Zero and span shift: ±0.15 % of max. span

Mounting position effect

Zero error <0.32 kPa, which can be calibrated out.

Vibration effect (IEC 68-2-6: FC):

±0.1 % of measuring range/

2 g/10 to 2000 Hz

4 g/10 to 100 Hz

Power supply effect

<±0.01 % of calibrated span per volt.

EMC-test standards

CENERIC EMISSION STANDARD:

EN 50081 - 2: 1993

Normative reference:

EN 55022:1987/class A

GENERIC IMMUNITY STANDARD:

EN 50082 - 2: 1995

Normative references:

EN 61000-4-2, -4, -5, -8, -11

ENV 50140, ENV 50204, ENV 50141

Insulation test voltage

500 V rms 50 Hz.

CONSTRUCTION AND CALIBRATION

Materials

Diaphragm ¹⁾: AISI316L, Hast. C276 or Tantalum.

Sensing element ¹⁾: AISI316, PTFE/ AISI316 or PVC

Other materials: SIS2343

Fill fluid Silicone oil or inert oil.

Housing with PLUG connector, codes H and T

Housing: AISI316

Seals: Viton® and NBR

TEST jacks: MS358Sn/PVDF, protected with silicone rubber shield. PLUG connector: PA6-GF30 jacket, Silicone rubber seal, AISI316 retaining screw.

Housing with junction box/terminal strip, codes M and N

Housing: AISI303/316; Seals: Nitrile and Viton®; Nameplates: Polyester

Connection cable between sensing element and housing (code Land K):

PTFE hose with AISI316 braiding.

Equipment cabinet Rittal AE1380, Steel cabinet with polyester paint.

Enclosure class: IP66.

¹⁾ Parts in contact with process medium

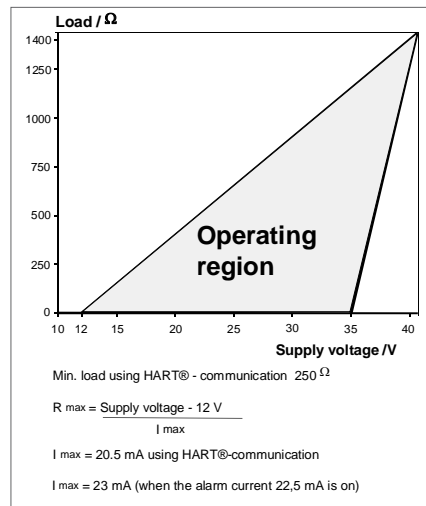

Calibration

For customer-specified range with minimum damping. (If range is not specified, transmitter is calibrated for maximum range.)

Electrical connections

Housing with PLUG connector, codes H and T:

PLUG connector, connector type DIN 43650 model AF; Pg9 gland for cable; wire gross-section 0.5 to 1.5 mm².

Housing with junction box/terminal strip, codes M and N: M20x1.5, 1/2-NPT inlet; screw terminals for 0.5 to 2.5 mm² wires.

Process connections

DN50PN40, DN80PN40, ANSI2" 150 lbs/300 lbs, ANSI3" 150 lbs/300 lbs; clamp mounting on angle bracket (see INSTALLATION)

Weight (kg):

· VVF 2.2 kg

· VVP 8.7 kg

· VVH 9.2 kg

+ 1 kg/m with PVC protective tube and 3 kg/m with AISI316 protective tube

Pressure limits			Minimum process pressure		
Maximum process pressure, MPa			Minimum process pressure for different fill fluids (kPa,abs.)		
Transmitter type	Max. overload pressure	Pressure class	T _{proc.} °C	DC200 100 cSt	Inert oil
VV...4	0.3	PN40	20	5	8
VV...5	1.5	PN40	40	8	10
			80	16	28

Dimensional drawings (drawings in mm)

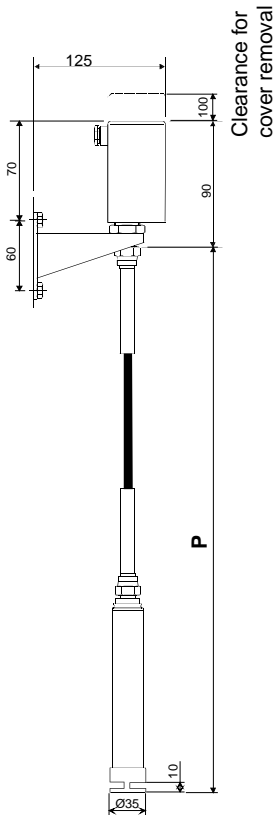

Type VVF

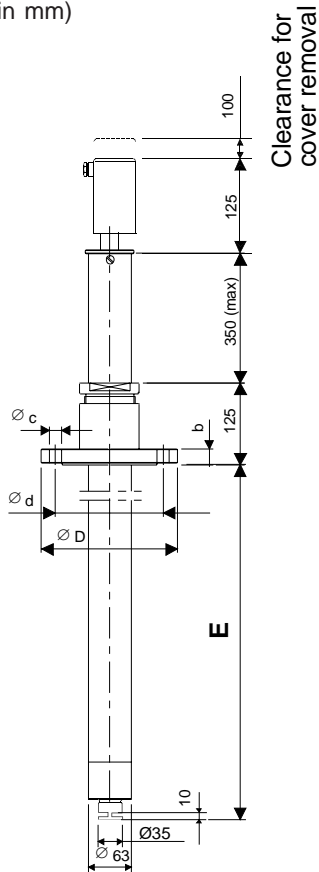

Type VVP

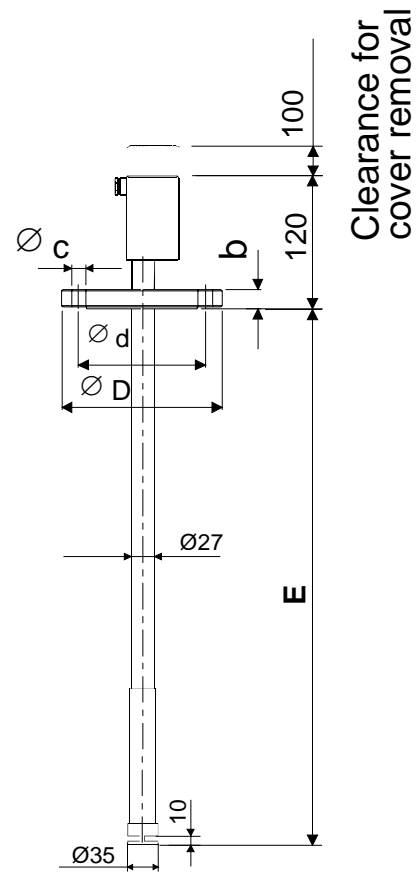

Type VVH

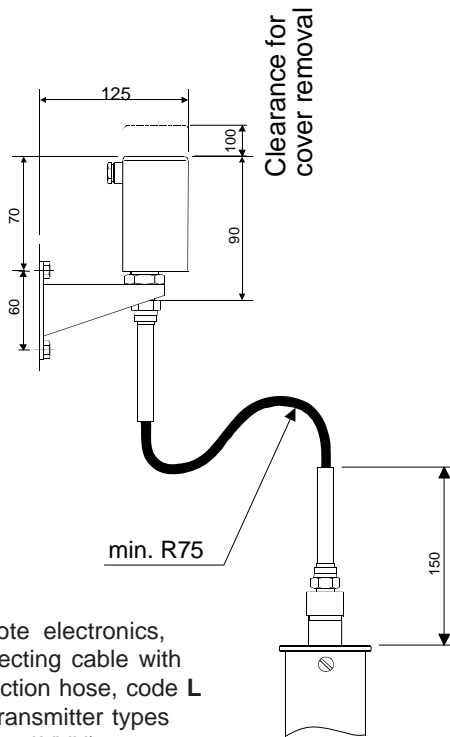

Remote electronics, connecting cable with protection hose, code L (for transmitter types VVP and VVH)

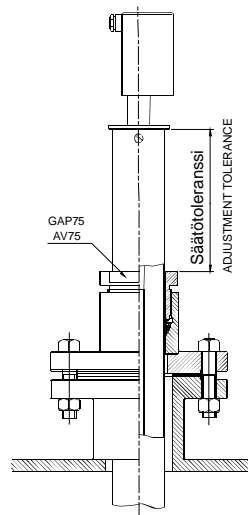

Flange mounting with adjustment facility, type VVP

Flange	Code	ØD	Ød	Øc	b
DN50 PN40	DB	165	125	4x18	20
DN80 PN40	DC	200	160	8x18	24
ANSI2"150lb	AC	152	120.6	4x20	23
ANSI2"300lb	AD	165	127	8x20	25
ANSI3"150lb	AE	191	152.4	4x20	26
ANSI3"300lb	AF	210	168.3	8x23	31

Type	P/m		E/m	
	min.	max.	min.	max.
VVF	1.0	20.0	-	-
VVP	-	-	1.0	5.5
VVH	-	-	1.0	5.5

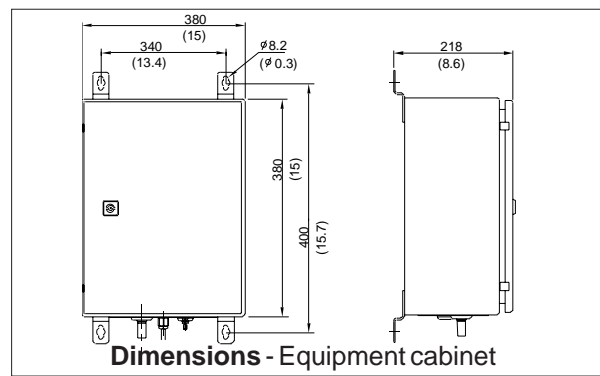

SATRON VV pressure transmitter

Installation methods

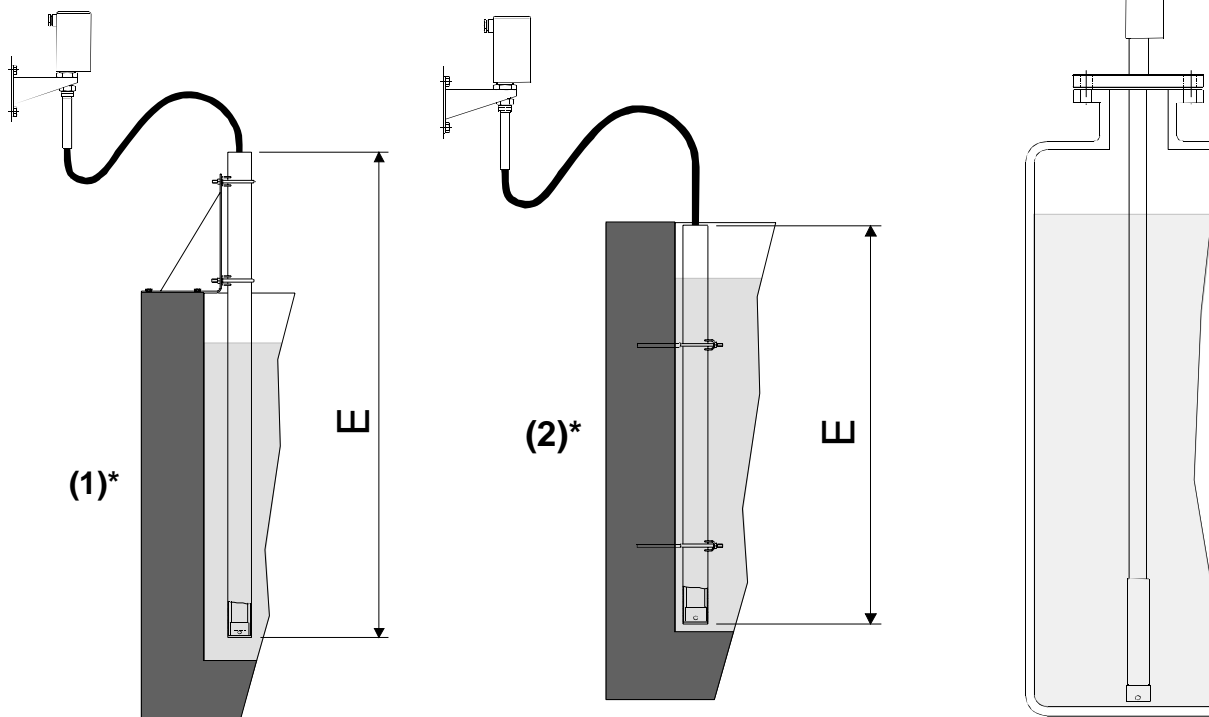

*) See the selection table "Other mounting accessories"

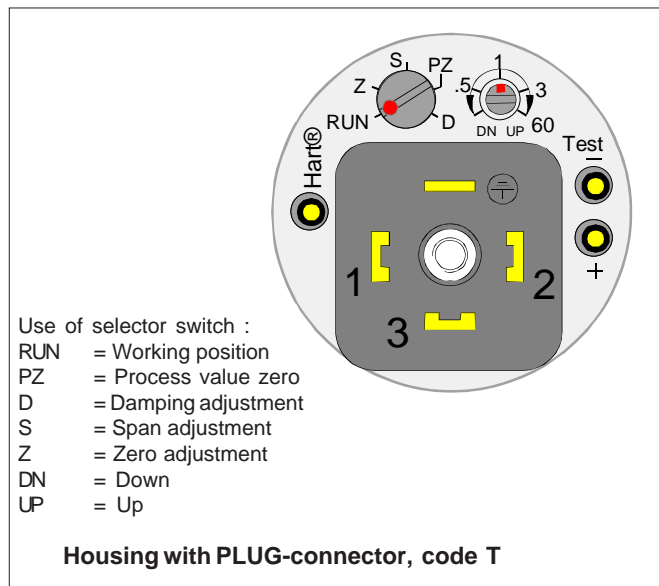
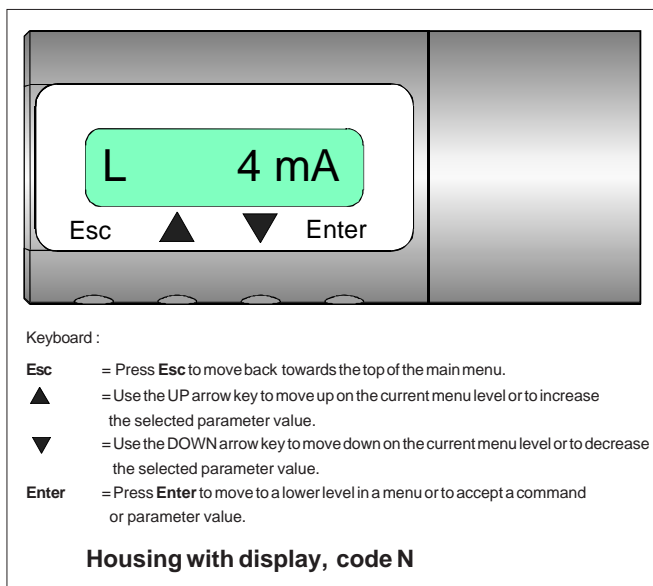
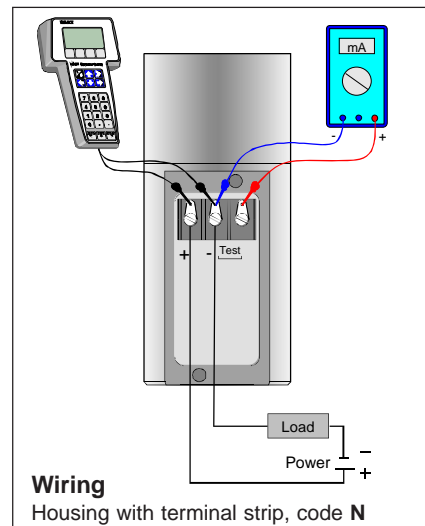
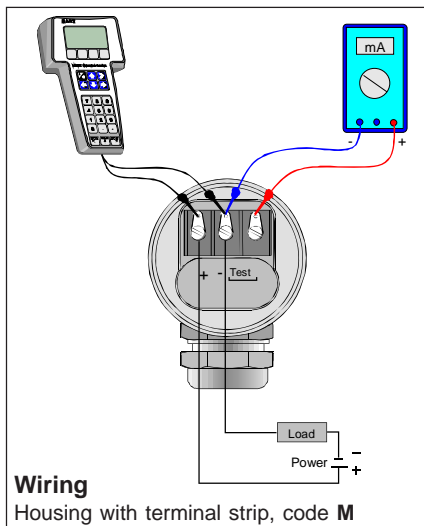
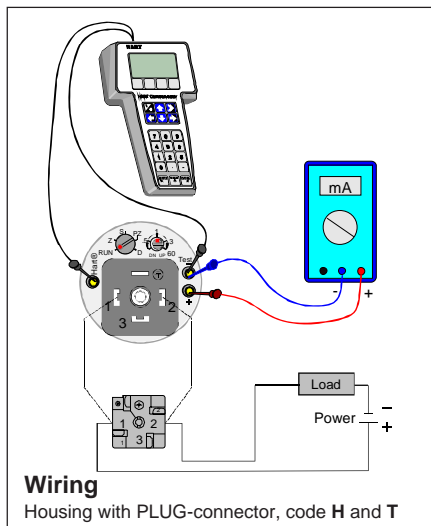

Selection Chart

Transmitter types			
VVF	Flexible PTFE hose (PTFE/AISI316 braiding)		
VVP	PVC hose/Flange		
VVH	AISI316L hose/Flange (Fixed mounting tube)		
Adjustability	Span, min.	Span, max.	Measuring range
4	4kPa (40 mbar)	100 kPa (1000 mbar)	-100...+100 kPa (-1000...1000 mbar)
5	26.5 kPa (265 mbar)	200 kPa (2000 mbar)	-100...+200 kPa (-1000...2000 mbar)
Output	S 4-20mA DC/HART® -protocol		
Flange	0 No flange	DB DN50 PN40	DC DN80 PN40
	AD ANSI 2" 300 lbs	AE ANSI 3" 150 lbs	AF ANSI 3" 300lbs
Wetted materials	Code	Flange Material	Diaphragm Code
	2	AISI316L	2
	3	Hast.C 276	3
			5
			Tantalum
			Extension
			(type VVF=PTFE/AISI316)
			(type VVP=PVC)
			(type VVH=AISI316)
Fill fluid	S Silicone oil		
	G Inert oil		
Housing type			
H	Housing with PLUG-connector, DIN43650, no display, inlet PG9		
T	Housing with PLUG-connector with manual adjust, DIN43650, no display, inlet PG9		
M	Housing with junction box/terminal strip, no display, inlet M20x1,5		
N	Housing with junction box/terminal strip, with display, inlet M20x1,5		
C	Transmitter with equipment cabinet (for transmitter type VVF and for special electronics)		
D	Transmitter with equipment cabinet + heating element (for transmitter type VVF and for special electronics)		
Explosion proof	0 No explosion proof classification		1 EEx ia IIC T4 (not ATEX)
Length P of PTFE/AISI316 hose between sensing element and housing (specify for transmitter type VVF)			
	P10 1.0 m hose		
	P25 2.5 m hose		
	P200 20.0 m hose		
Length E of mounting/protective tube (specify for transmitter type VVP and VVH also with the type VVF if the protective tube is used)			
	E10 1.0 m hose		
	E15 1.5 m hose		
	E55 5.5 m hose		
Other mounting accessories	0 No mounting accessories		
	1 Mounting bracket/Clamps/Protective tube		
	2 Clamps/Protective tube		
Special size of electrical inlet			
N	1/2 NPT	G	Pg13.5
		P	PLUG-connector, DIN43650
Special features			
Special electronics (specify only if housing connected with hose to sensing element) for transmitter types VVP and VVH			
- connecting cable with protection hose			
L	Hose protected with PTFE/AISI316 braiding, straight		
K	Hose protected with PTFE/AISI316 braiding, angle of 90°		
Length of cable between sensing element and housing (specify only if housing connected with cable to sensing element)			
2	2 m cable		
3	3 m cable etc. (max. 10 m)		
Mounting parts for remote electronics for Ø51 mm tube			
0	No mounting parts		
1	Mounting parts		
Documentation			
Calibration Certificate	AE English		
Installation and Operating Instructions	IE English	IF Finnish	
Material Certificates			
0	No material certificate		
MC1	Raw materials certificate without appendixes, in accordance with SFS-EN 10204-2.1 (DIN 50049-2.1) standard		
MC2	Raw materials certificate for wetted parts with appendixes, in accordance with SFS-EN 10204-2.2 (DIN 50049-2.2) standard		
MC3	Raw materials certificate for wetted parts with appendixes, in accordance with SFS-EN 10204-3.1B (DIN 50049-3.1B) standard		

We reserve the right for technical modifications without prior notice.
 HART is a registered trademark of HART Communication Foundation.
 Hastelloy is the registered trademark of Haynes International.
 Teflon is the registered trademark of E.I. du Pont de Nemours & Co.
 Viton is the registered trademark of DuPont Dow Elastomers.

